

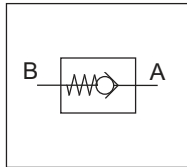

VUC20

Valvola unidirezionale a sfera
Check valve



Caratteristiche principali main features	
Pressione max max pressure	350 bar
Portata max max flow	25 l/min
Peso weight	0,07 Kg



Diagramma perdita di carico - pressure drop diagram



NB: Valori misurati sulla sola valvola.
La perdita di carico potrebbe variare a seconda della viscosità del liquido e della temperatura. Le curve sopra riportate sono state ottenute alla temperatura di 40°C, utilizzando olio con viscosità 46 cSt.
Note: Values measured on valve alone. Pressure drop may change depending on fluid viscosity and temperature. The curves above, have been obtained at 40°C, using oil with viscosity 46 cSt.

Lato serbatoio
tank side

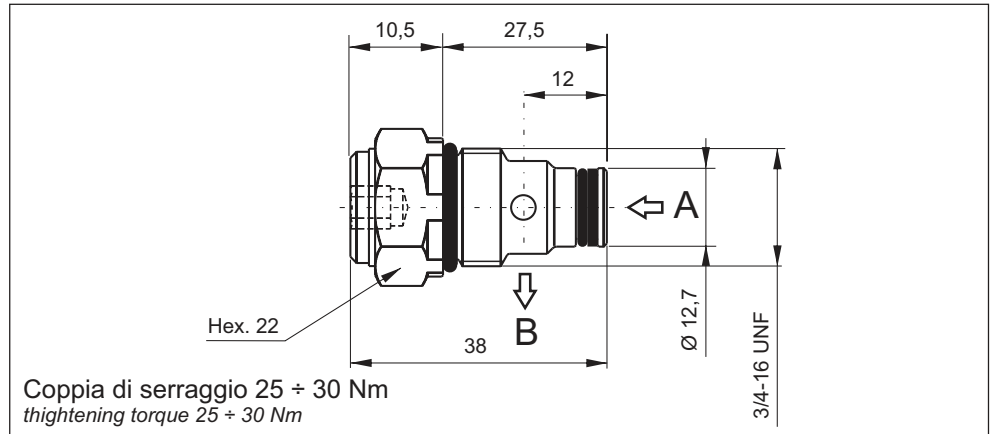
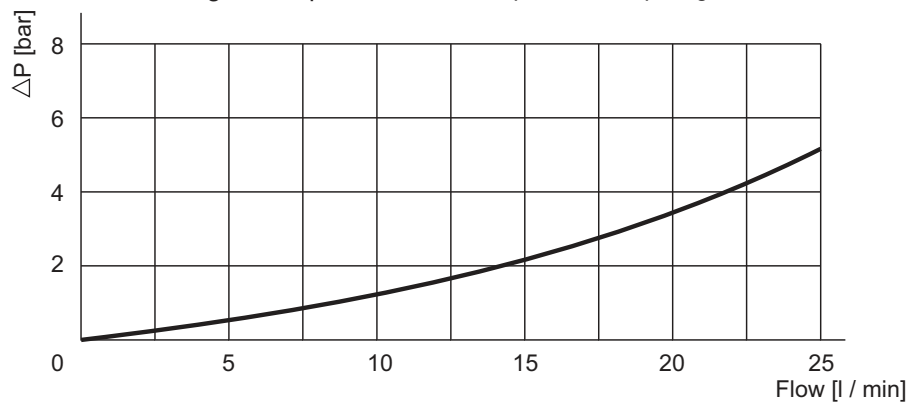
Collettore centrale
central manifold
Nell'esempio G02
In this example G02

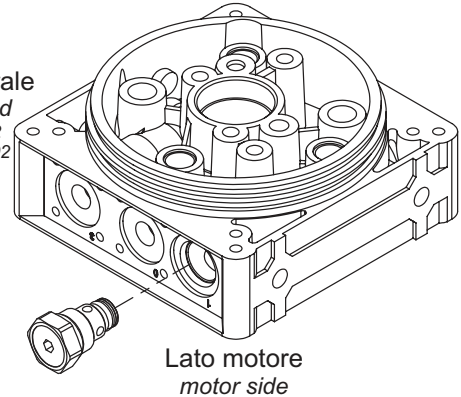

Lato motore
motor side

Codice ordinazione - ordering code



1 Tipo di valvola - valve type
VUC

2 Grandezza nominale - nominal size
3/4"-16 UNF

3 Serie - series
0 = Standard