

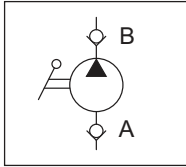

## PM02

Pompa manuale  
Hand pump

Caratteristiche principali main features	
Pressione max max pressure	200 bar
Cilindrata displacement	2 cc/rev
Peso weight	0,40 Kg

NB: Valori misurati sulla sola valvola.  
Note: Values measured on valve alone.

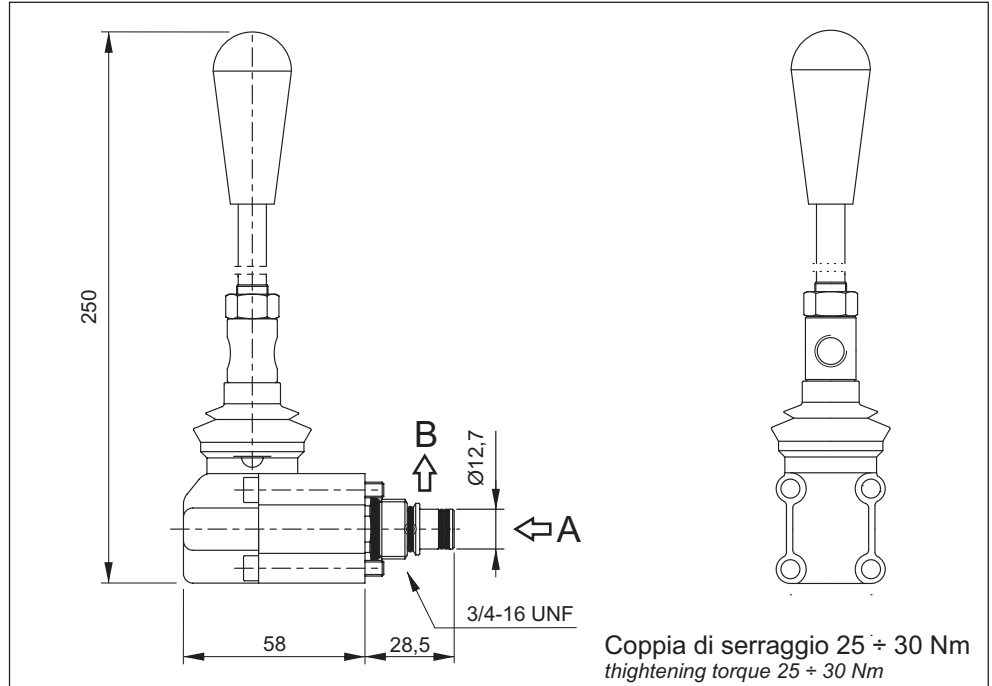

Coppia di serraggio 25 ± 30 Nm  
tightening torque 25 ± 30 Nm

## Diagramma forze azionamento - actuating forces diagram

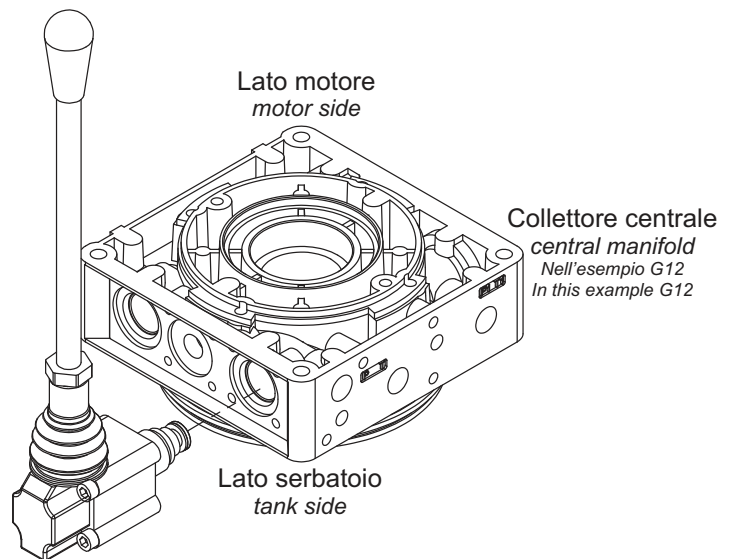
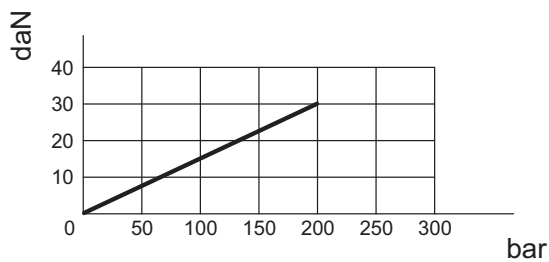

## Codice ordinazione - ordering code



1 Tipo di valvola - valve type  
PM02

2 Serie - series  
0 = Standard